

# OSAKA COLLECTION

ASSEMBLY INSTRUCTIONS



## THESE INSTRUCTIONS APPLY TO THE FOLLOWING MODELS:

- Osaka with and without headboard
- Nara with and without headboard

We recommend two people to assemble this bed base.

*Illustrations are not to scale.  
Please note, single beds  
will include less fittings.*

## FITTINGS FOR ASSEMBLY

*(the only other tool you'll need is a cross-head screwdriver - we do not recommend the use of a drill for assembly)*

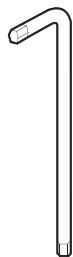

1x HEXAGON  
KEY

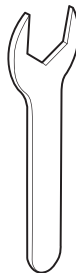

1x SPANNER\*

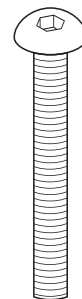

6x HEX KEY  
BOLTS

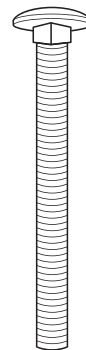

3x HEADBOARD  
BOLTS\*

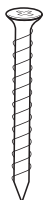

4x SCREWS



3x HALF MOON  
WASHERS\*

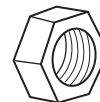

3x NUTS\*



4x WASHERS

*\*Only included for beds  
with a headboard*

# 1.

*\*If you have ordered a single bed, there will not be a centre rail or central legs - please start from step 4.*

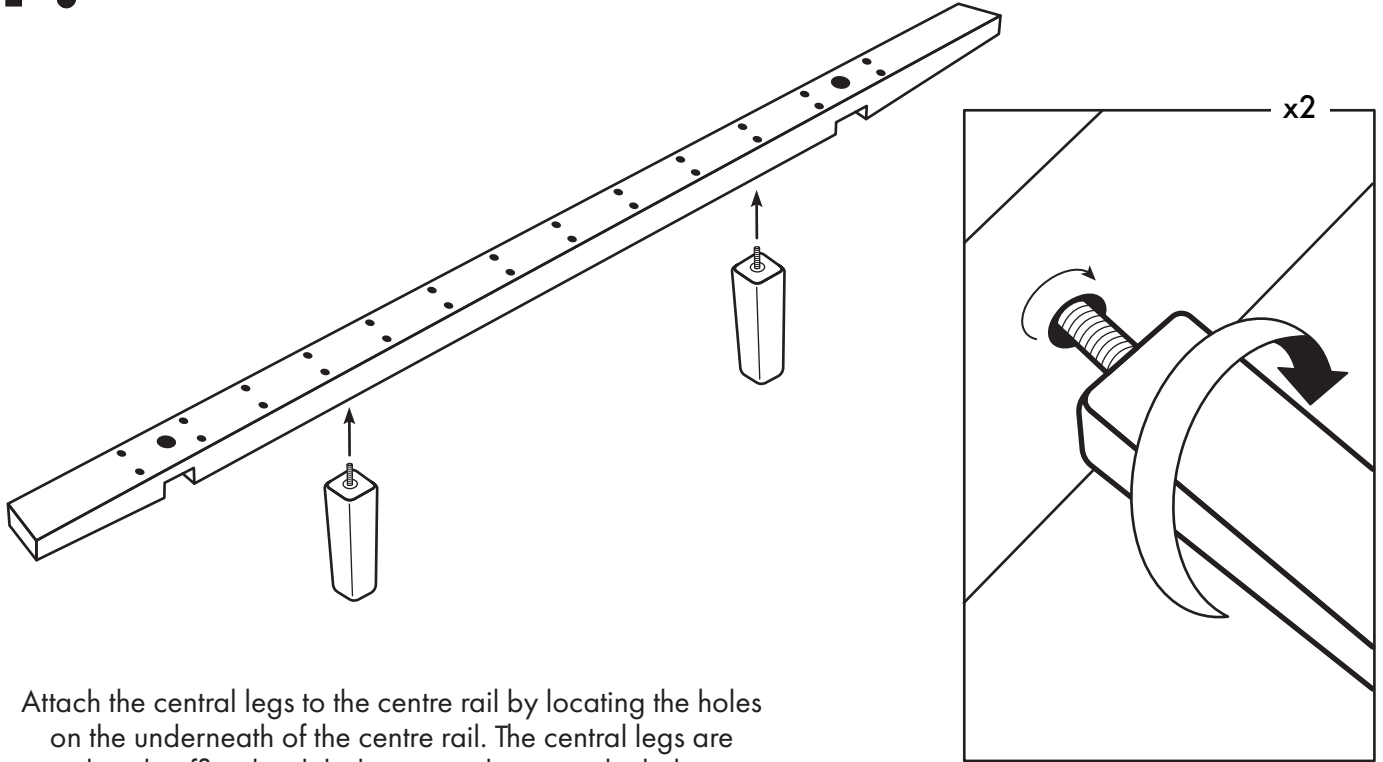

Attach the central legs to the centre rail by locating the holes on the underneath of the centre rail. The central legs are already affixed with bolts- screw them into the holes.

# 2.

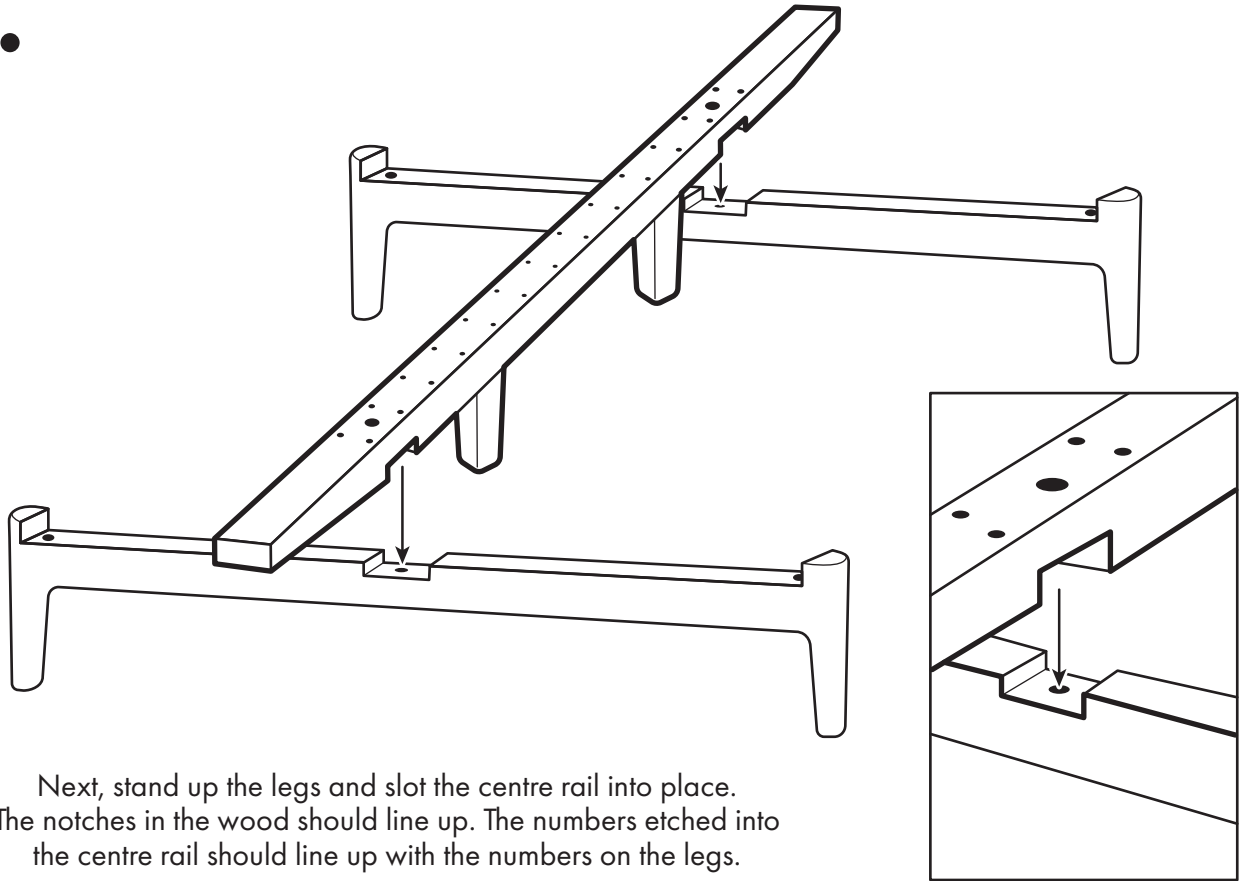

Next, stand up the legs and slot the centre rail into place. The notches in the wood should line up. The numbers etched into the centre rail should line up with the numbers on the legs.

# 3.

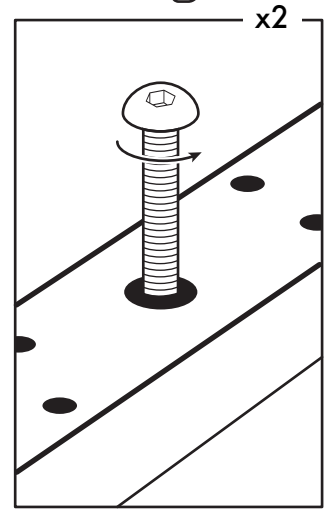
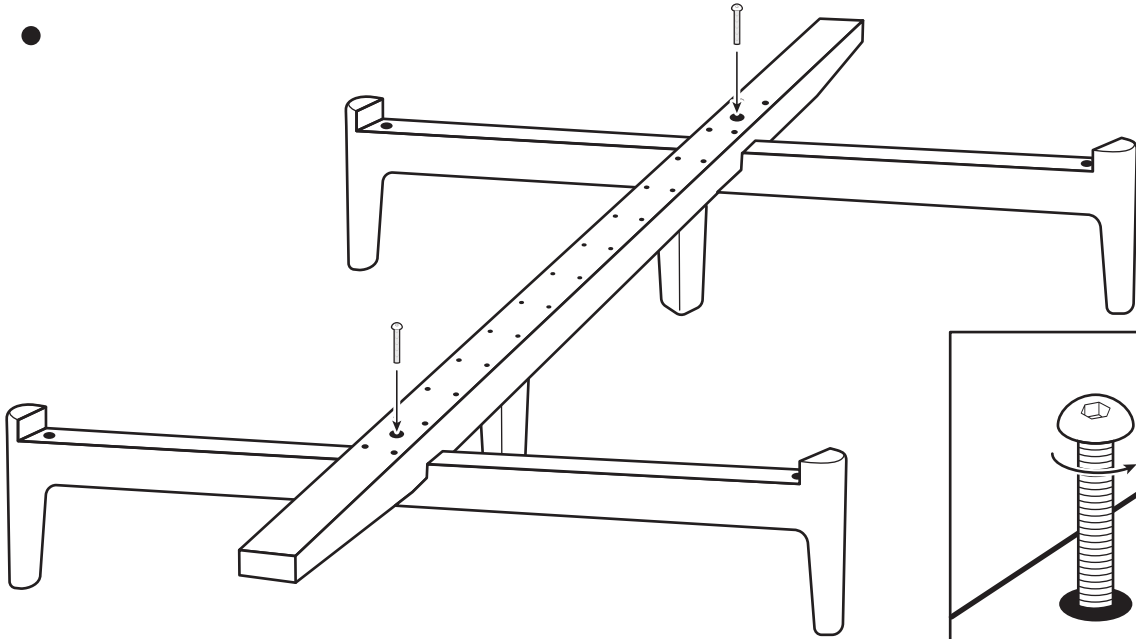

Take two of the hex-key bolts and insert them into the centre rail and through to the legs. **DO NOT** tighten fully or use the allen key just yet. Hand-tighten to hold everything in place for now.

# 4.

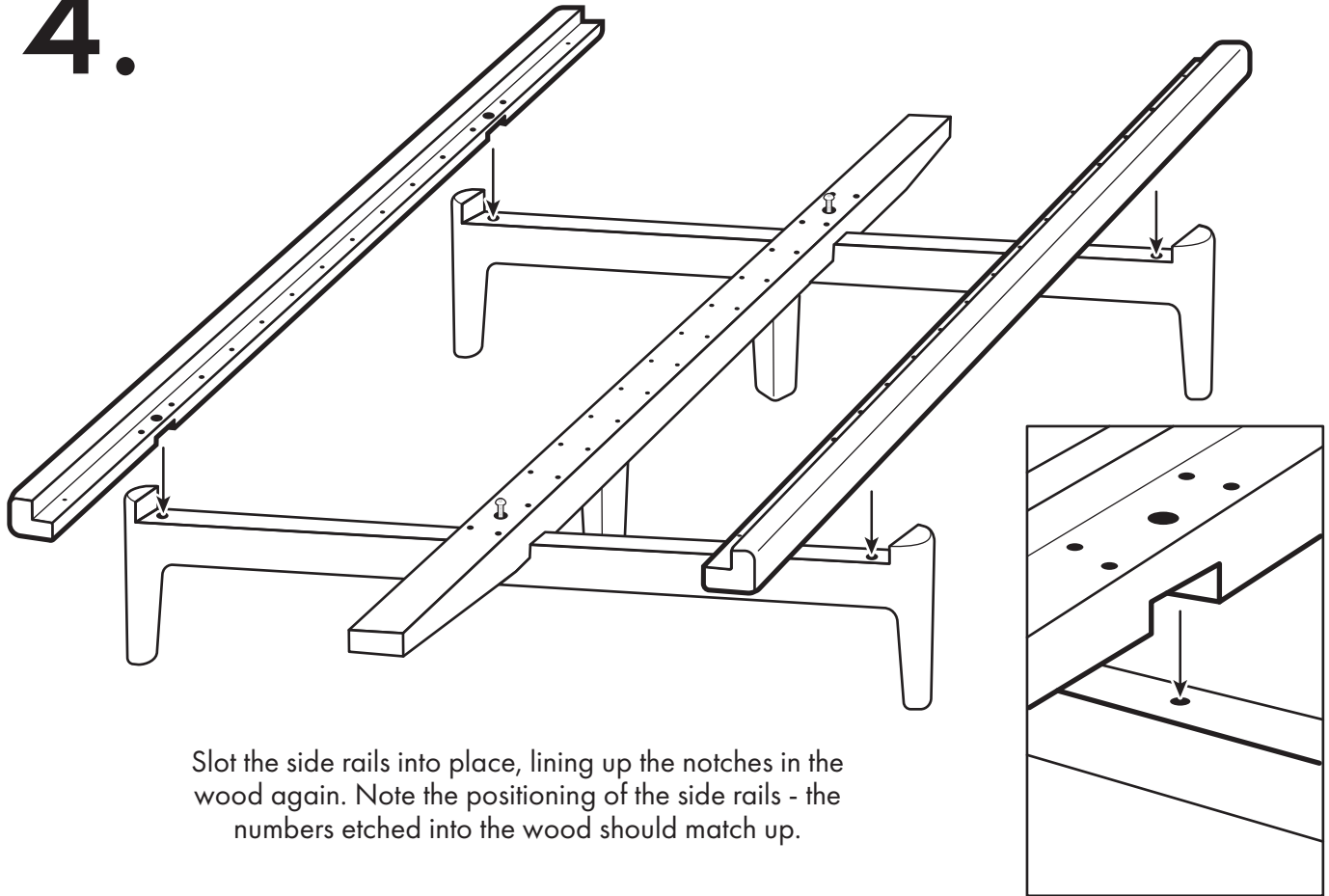

# 5.

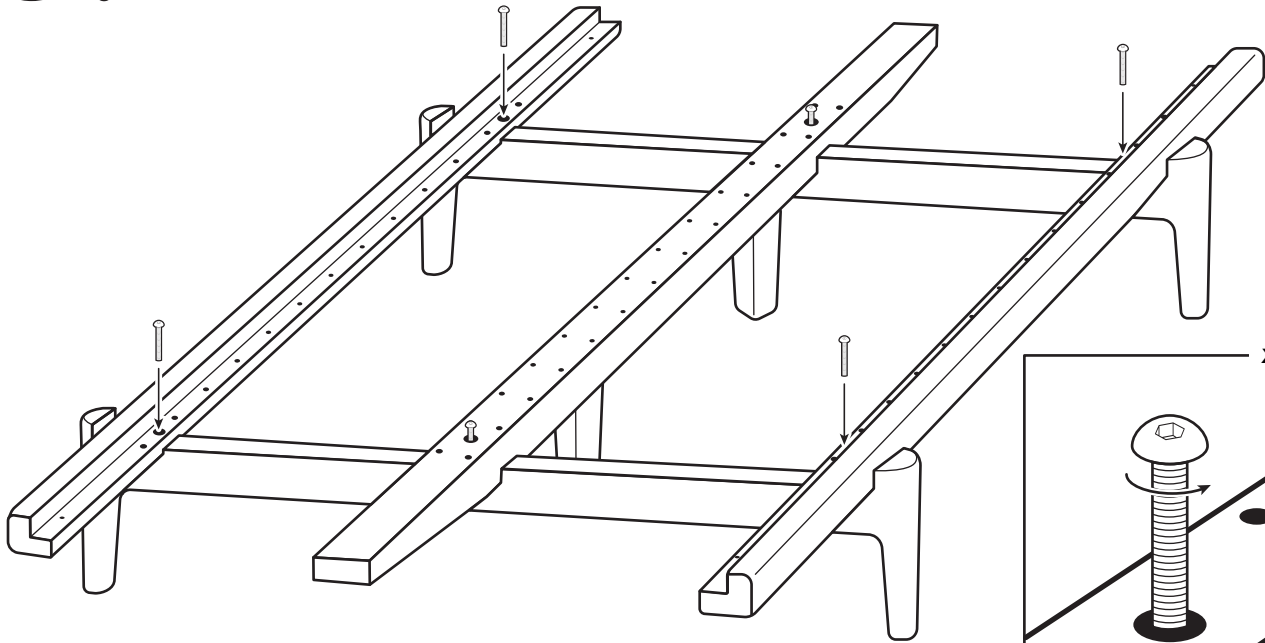

Insert the remaining four hex-key bolts through the side rails and into the legs. Again, **DO NOT** tighten fully or use the allen key just yet. Hand-tighten to hold everything in place for now.

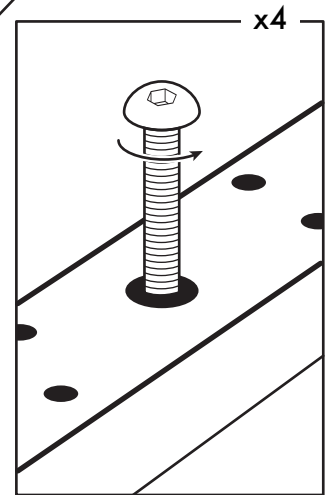

# 6.

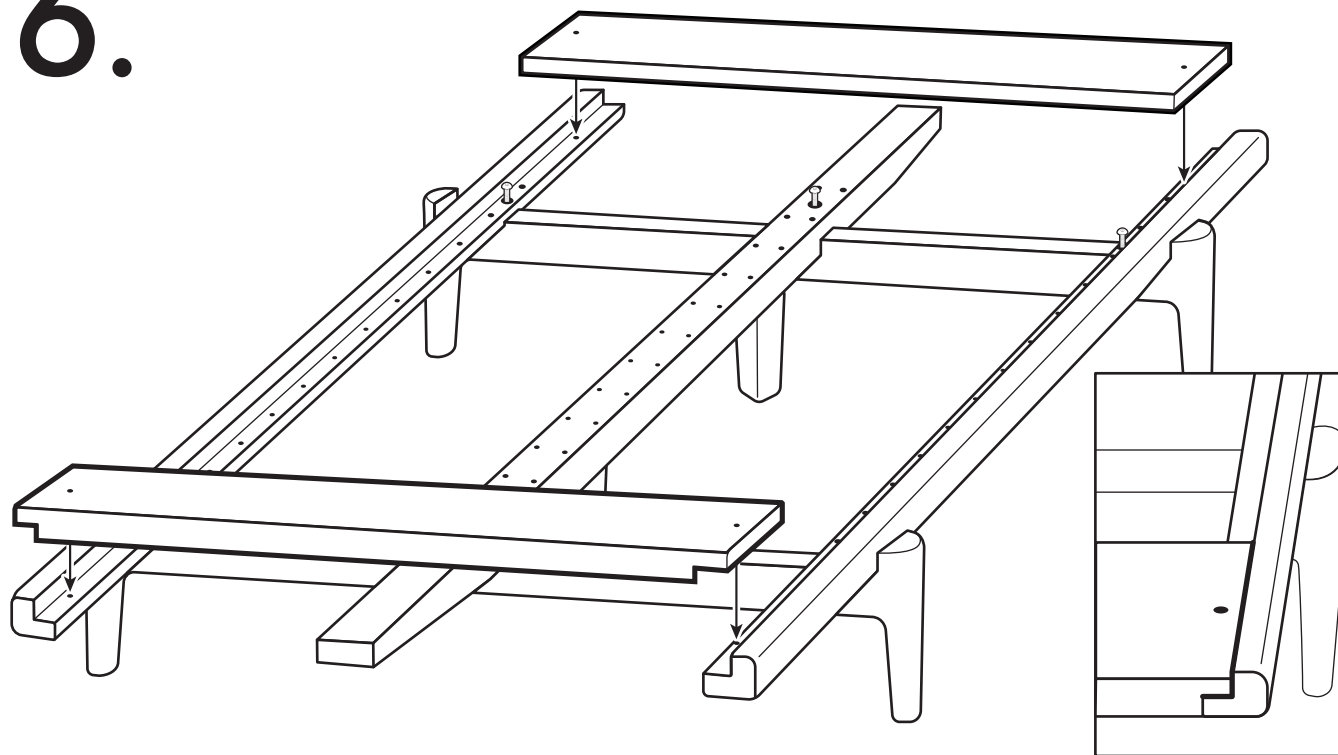

Slot the end-panels into place.

*\*Please note, you will have received 1x flat end panel and 1x stepped end panel.  
The stepped panel is placed to the foot-end, and the flat panel to the head-end.*

**Tip:** Lining up the edges of the end-panels will help you ensure that the bed is square, as the edges of the end panels and side rails should meet.

# 7.

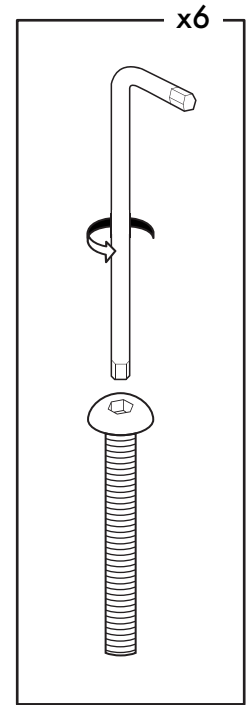
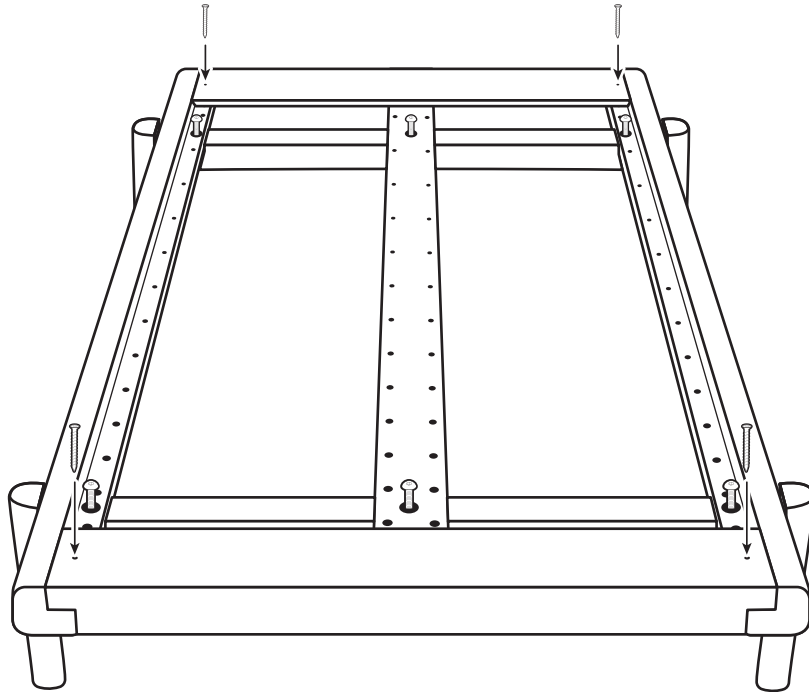
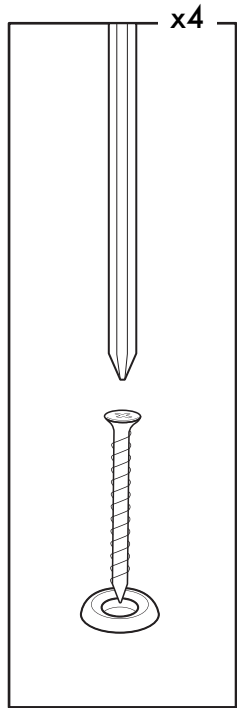

Stand back and ensure that the bed is square.

Once happy, tighten the bolts in the centre rail and side rails using the allen key provided. Then, place the brass washers over the holes on the end panels at the head and foot-end of the bed. Screw the screws into these holes (through the washers), using a cross-head screwdriver (not provided).

# 8.

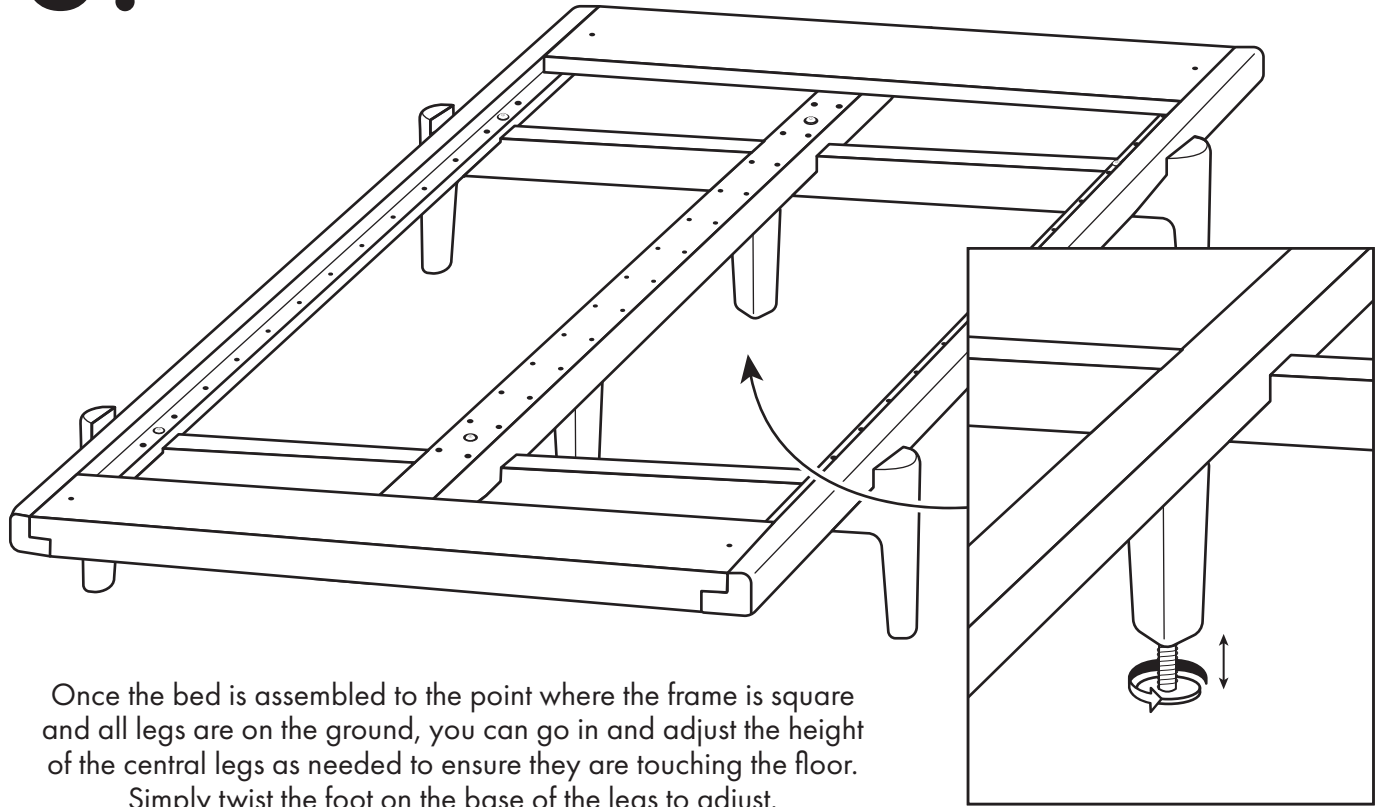

Once the bed is assembled to the point where the frame is square and all legs are on the ground, you can go in and adjust the height of the central legs as needed to ensure they are touching the floor. Simply twist the foot on the base of the legs to adjust.

**If you've ordered a bed  
without a headboard,  
please skip to step 12.**

**If you've ordered a bed  
with a headboard, please  
proceed to step 9.**

# 9.

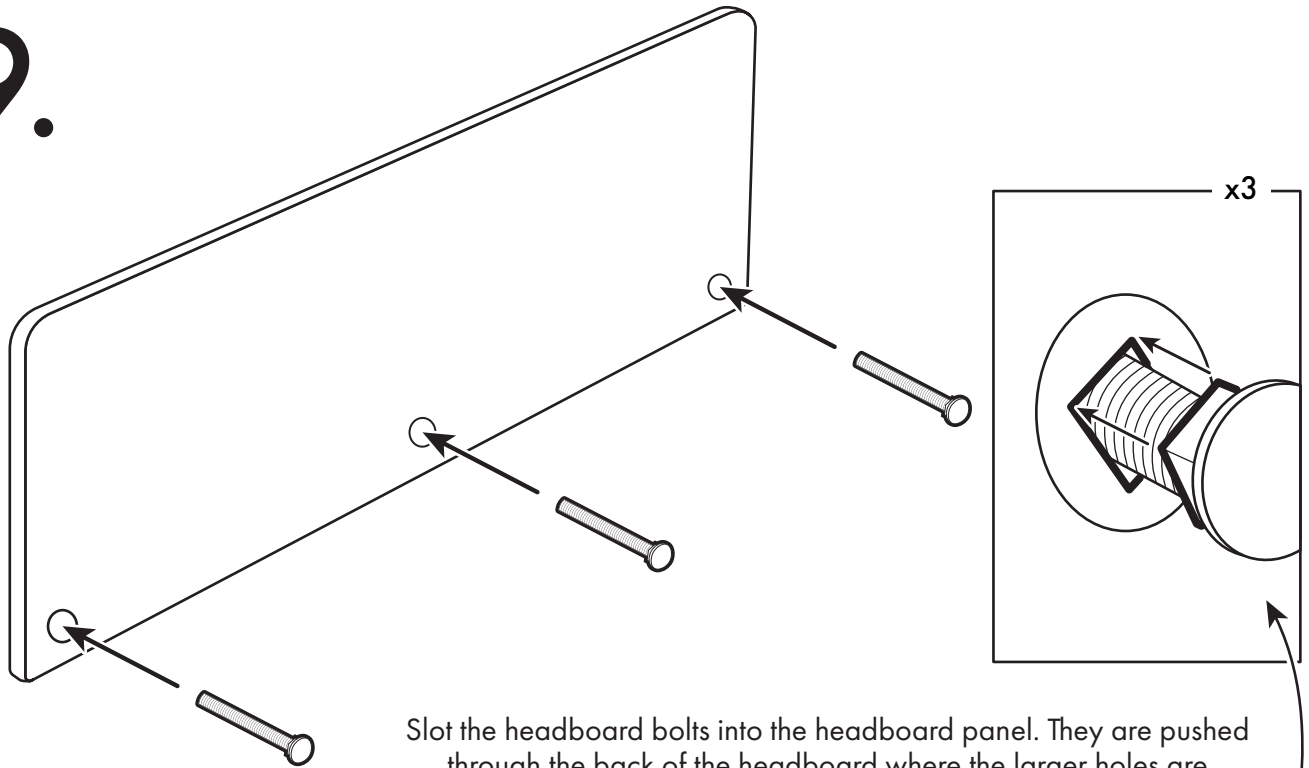

Slot the headboard bolts into the headboard panel. They are pushed through the back of the headboard where the larger holes are located. The front of the headboard features smaller holes.



The bolts have a square shape beneath the bolt head. When pushing the bolts into the headboard panel, ensure that this square matches up with the square notch found within the holes on the headboard panel.

# 10.

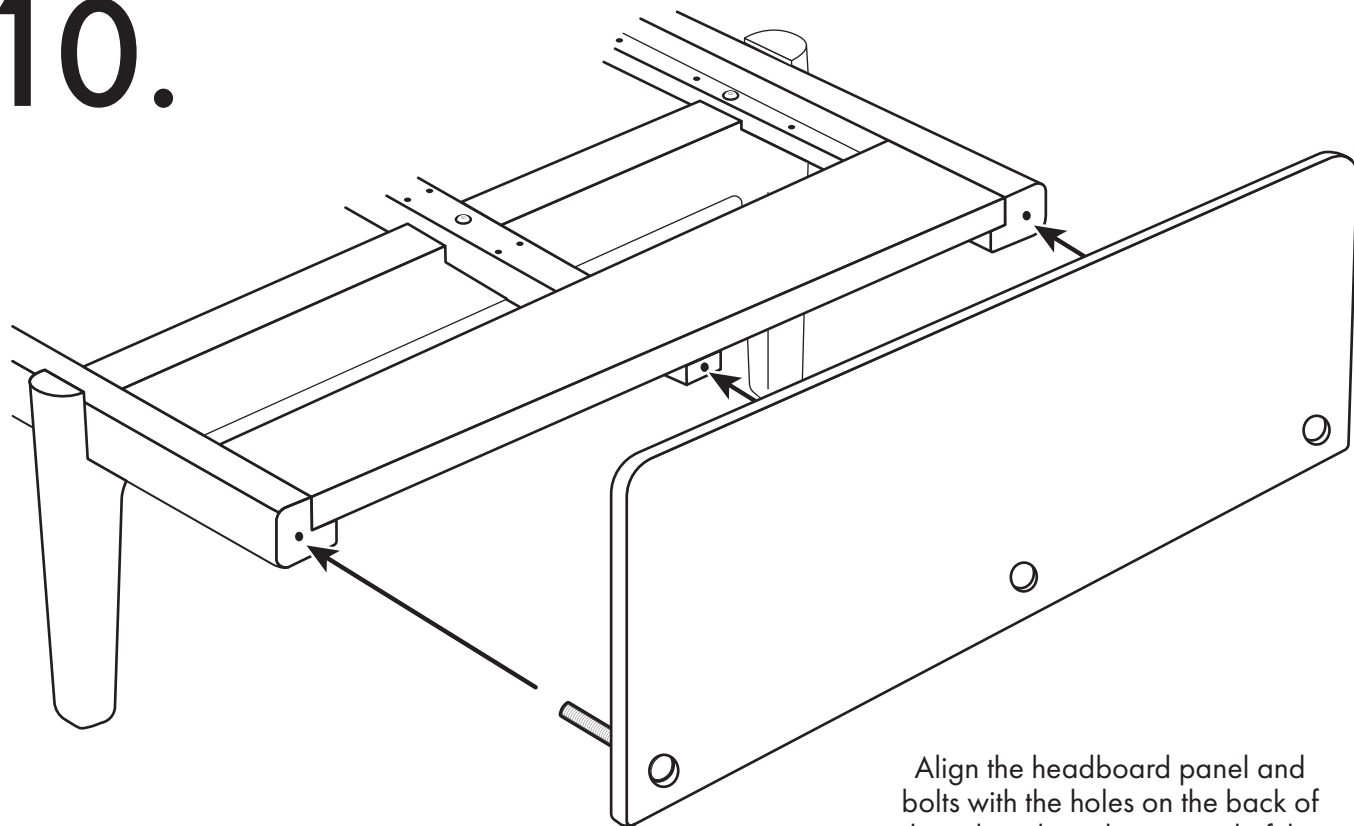

Align the headboard panel and bolts with the holes on the back of the side rails and centre rail of the bed. Push into place.

# 11.

Working from underneath the bed frame, slide the half moon washer and nut onto each of the bolts. Tighten the nuts using the spanner provided.

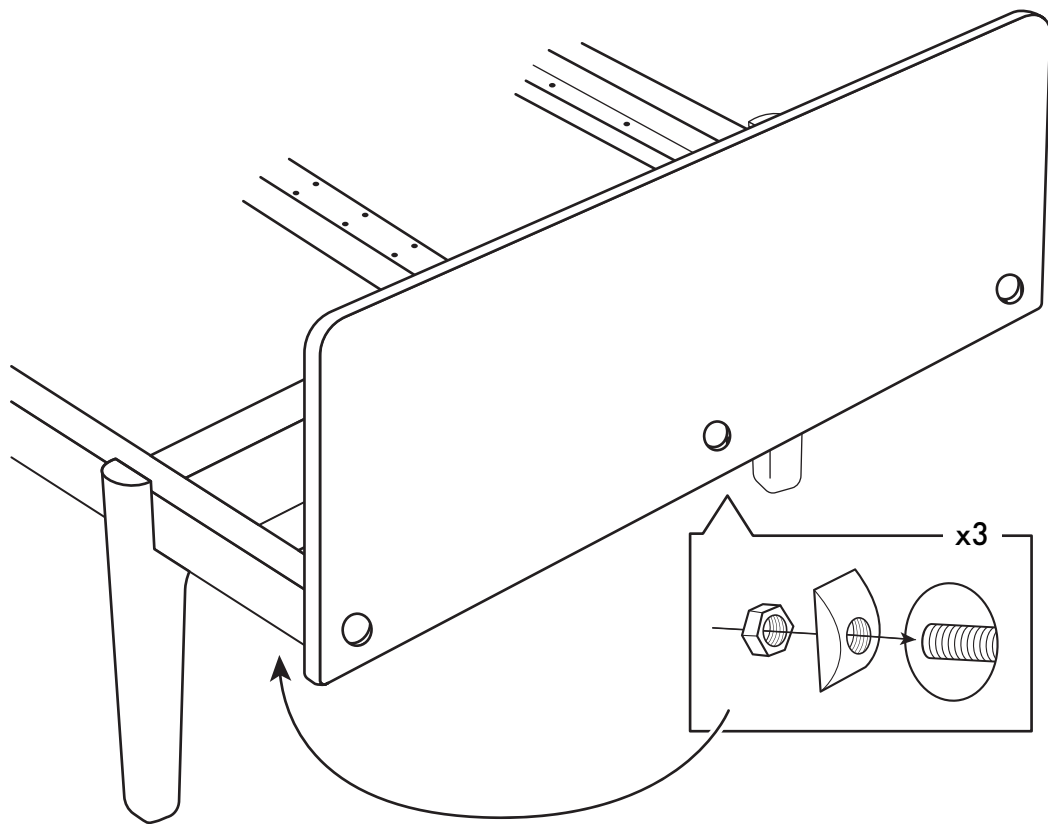

# 12.

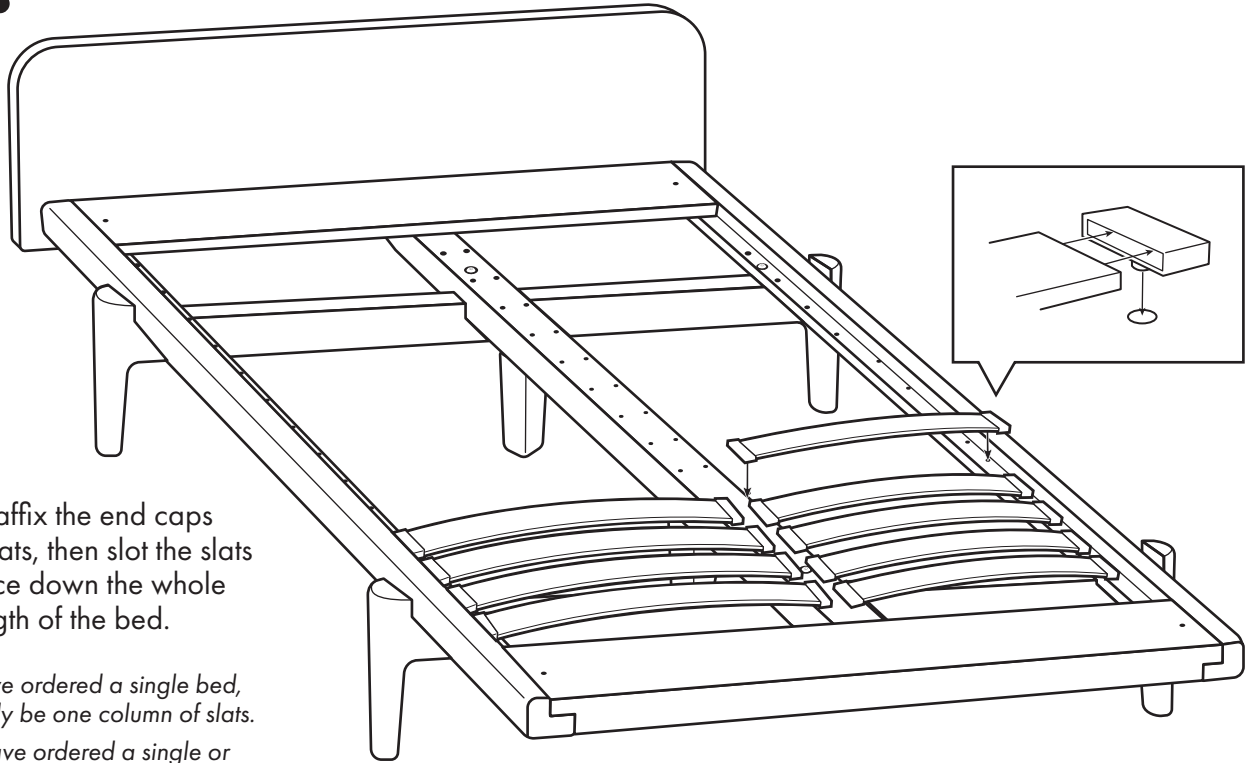

Lastly, affix the end caps onto the slats, then slot the slats into place down the whole length of the bed.

*\*If you have ordered a single bed, there will only be one column of slats.*

*\*If you have ordered a single or superking bed, or a bed with solid pine slats, separate instructions will be included for your slat system.*

THANK YOU FOR BUYING A BED FROM

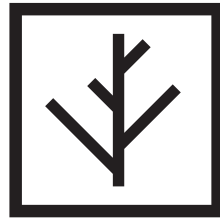

**NATURAL BED  
COMPANY**

DEVONSHIRE POINT, 123-125 FITZWILLIAM STREET, SHEFFIELD, S1 4JP

0114 272 1984

[sales@naturalbedcompany.co.uk](mailto:sales@naturalbedcompany.co.uk)

[www.naturalbedcompany.co.uk](http://www.naturalbedcompany.co.uk)